

FIELD FABRICATE CURB
FLASHINGS FROM FLAT SHEET

CONTACT AEP SPAN REPRESENTATIVE
IF ADDITIONAL ROOF PENETRATION
INFORMATION IS REQUIRED.

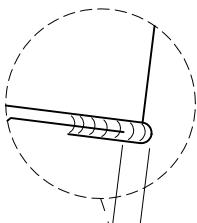
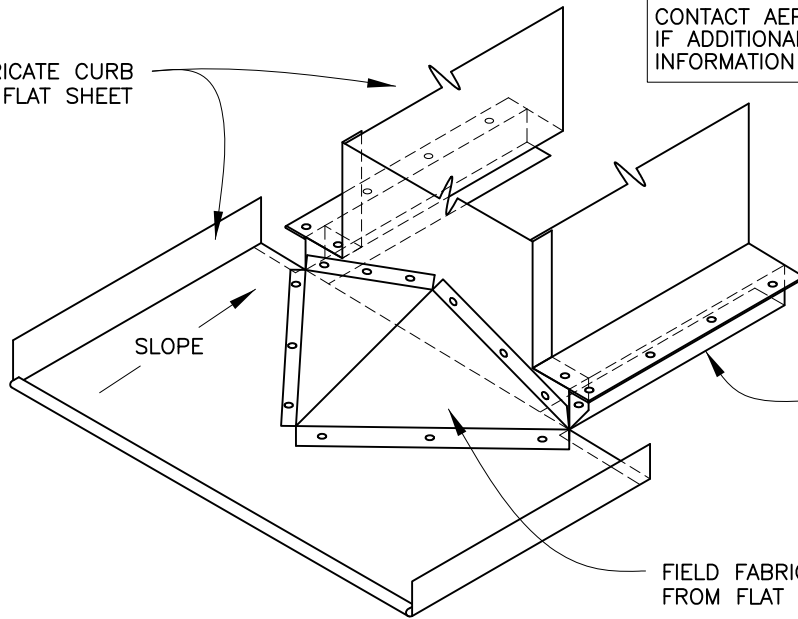

EQUIPMENT TRIM
(NOT BY AEP-SPAN)

CLEARANCE FOR
THERMAL MOVEMENT
PER CALCULATIONS

FASTENER
(NOT BY AEP-SPAN)

CRICKET TO BE
FIELD FABRICATED
FROM FLAT STOCK

FIELD FABRICATED
HEADWALL TRIM

1/8" RIVET
@ 12" O.C.

FASTENER
(NOT BY AEP-SPAN)

8" MIN

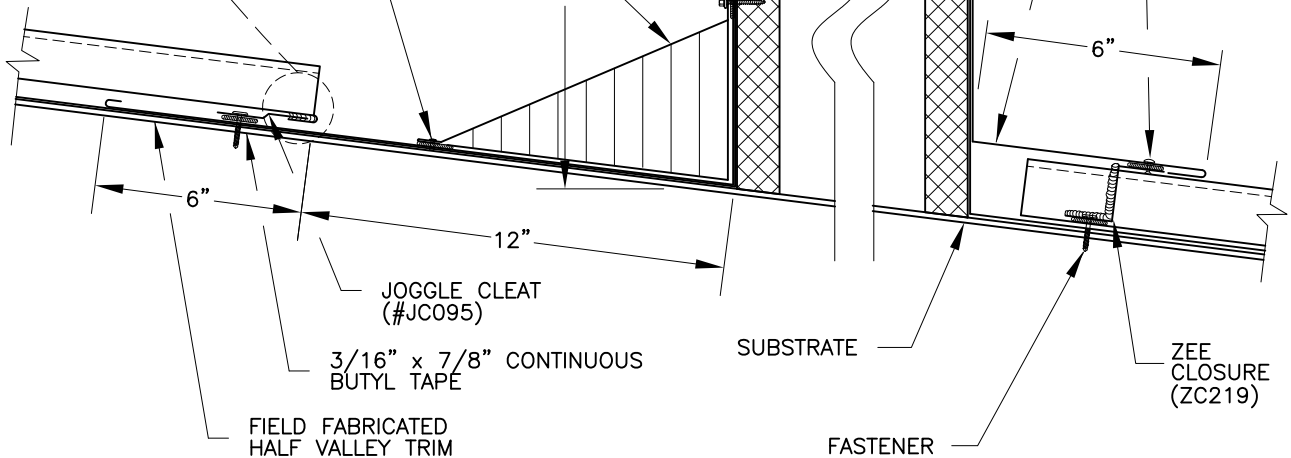

NOTE:
CURBS 24" WIDE OR GREATER REQUIRE USE OF CRICKETS.
CRICKETS OPTIONAL ON NARROWER CURBS.



DESIGN SPAN HP



ROOF CURB (UPHILL /
DOWNHILL DETAIL)

DS-22